

LINCOLN UNIVERSITY OBSTACLE COURSE



CHALLENGE DESIGN
PINEOLA, NORTH CAROLINA
PO BOX 219
828-737-6850
CHALLENGEDESIGN.COM

OWNER:

LINCOLN UNIVERSITY
DR. DARIUS WATSON, PH.D.
EXECUTIVE DIRECTOR OF ACADEMIC INITIATIVES
OFFICE OF ACADEMIC AFFAIRS
820 CHESTNUT STREET, 206B YOUNG HALL
JEFFERSON CITY, MO 65101
T: 573-681-5216
E: WATSOND@LINCOLN.U.EDU

DESIGNER:

CHALLENGE DESIGN INNOVATIONS
COREY WALL, OWNER
PO BOX 219
PINEOLA, NC 28662
T: 828-737-6850
E: DESIGN-BUILD@CDIINFO.COM

DRAWING INDEX:

- CDI 01 COVER PAGE
- CDI 02 SITE PLAN - PLAN VIEW
- CDI 03 COURSE PLAN - PLAN VIEW
- CDI 04 COURSE PLAN - ISOMETRIC VIEW
- CDI 05 STRUCTURAL NOTES
- CDI 06 TYPICAL DETAILS
- CDI 07 HORIZONTAL LADDER DETAIL
- CDI 08 LOW BELLY OVER DETAIL
- CDI 09 10, 8 FOOT WALL DETAIL
- CDI 10 HIGH STEP OVER DETAIL
- CDI 11 SWING STOP JUMP/ROPE CLIMBS DETAIL
- CDI 12 INCLINE WALL DETAIL
- CDI 13 SIX VAULTS DETAIL
- CDI 14 WEAVER DETAIL
- CDI 15 CULVERT CRAWL DETAIL
- CDI 16 PULL UP BARS DETAIL

LINCOLN UNIVERSITY
903 LAFEYETTE ST.
JEFFERSON CITY, MISSOURI, 65101
FOR CONSTRUCTION

COVER PAGE

DATE: June 1, 2023
DO NOT SCALE

CDI 01



NOTE:
 OBSTACLES ARE CENTERED ON THE
 5' BACK FROM THE EXISTING FENCE
 AND ARE SPACED 17' APART. FIELD
 ADJUST AS REQUIRED. MAINTAIN A
 MINIMUM OF 6" BETWEEN OBSTACLES.
 MAINTAIN MINIMUM OF 5' MINIMUM DEPTH
 (COMPUTED) BELOW OBSTACLES AS
 DETAILED IN CORREL PLAN.

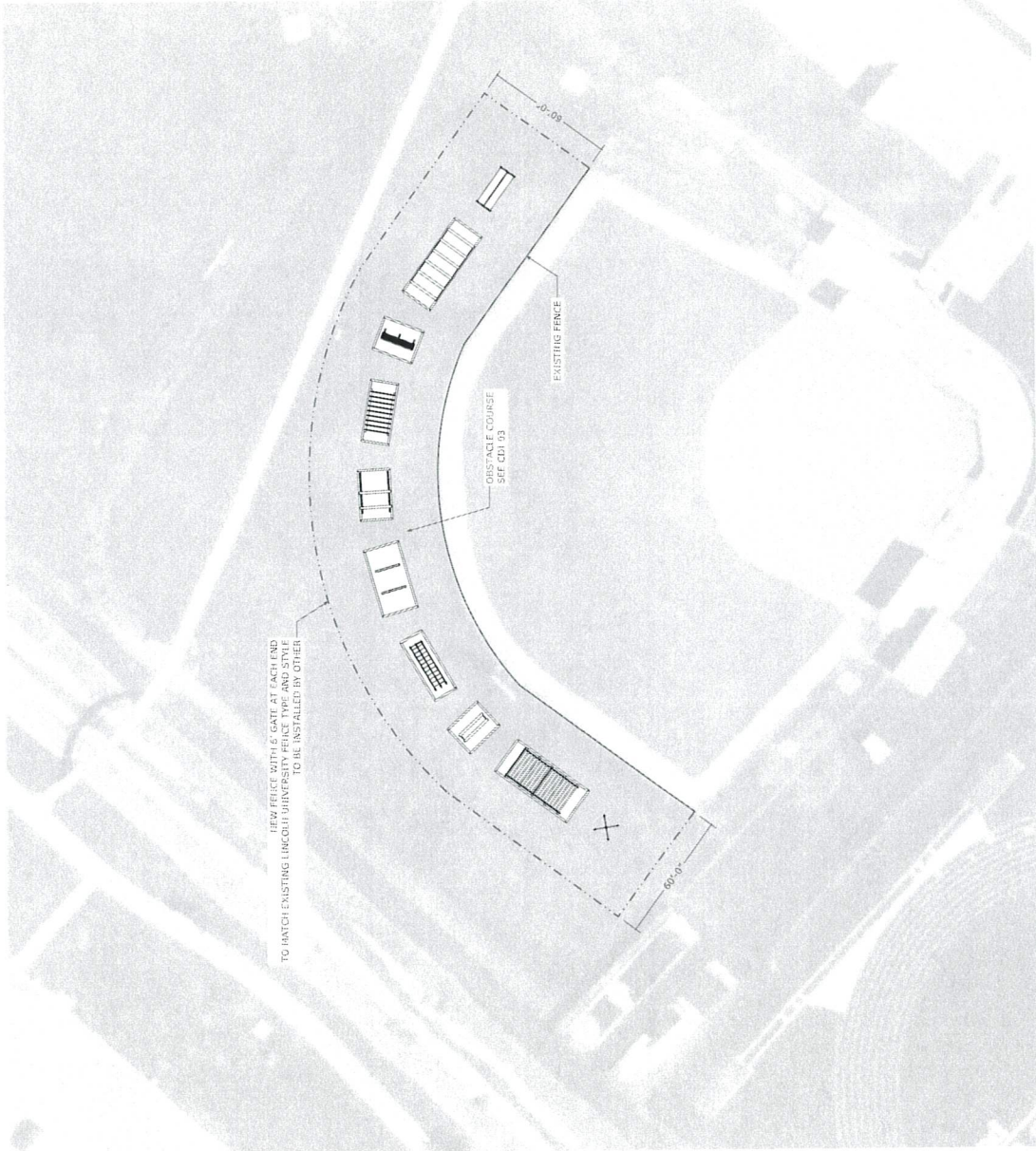

PLAN VIEW
 SHEETS

01



CHALLENGE DESIGN
 1015 W. UNIVERSITY BLVD.
 PO BOX 219
 PINEOLA, NORTH CAROLINA 28134
 828.737.6890
 CHALLENGEDESIGN.COM



LINCOLN UNIVERSITY
 903 LAURETTE ST.
 JEFFERSON CITY, MISSOURI, 65101
 FOR CONSTRUCTION

COURSE PLAN

DATE: June 1, 2023

DO NOT SCALE

CDI 03

NOTE:

OBSTACLES ARE CENTERED ON 30'-0" SETBACK FROM THE EXISTING FENCE AND ARE SPACED 17' AWAY FROM EACH OTHER TO MAINTAIN A MINIMUM OF 6' BETWEEN OBSTACLES.

MAINTAIN MINIMUM OF 5' MOUTH DEPTH TO ALL OBSTACLES AS DETAILED IN COURSE PLAN.

7" MIN. DIA. CGA TIMBER POLE, CHERRING PIN TO GROUND WITH 1/2" X 2" REBAR ATTACHED EVERY 5' ON CENTER TYPICAL.

TRANSFER (LOOSE-FILL RUBBER MULCH), BLACK 9" MINIMUM COMPACTED DEPTH WITH A 3/4" WEPD CONTROL FABRIC PHINED BELOW TYPICAL.

SWING STOP JUMP
 2" X 4" REBAR
 SEE CDI 11

HIGH STEP OVER
 SEE CDI 19

16'-8" FOOT WALLS
 SEE CDI 09

HORIZONTAL LADDER
 SEE CDI 07

LOW BELLY OVER
 SEE CDI 08

WEAVER
 SEE CDI 14

PULL UP MARKS
 SEE CDI 16

EXISTING FENCE



PLAN VIEW
 SCALE: 1/8" = 1'-0"

01



CHALLENGE DESIGN
 1715 W. ...
 PO BOX 219
 PINEOLA, NORTH CAROLINA
 28134
 808.727.4680
 CHALLENGEDESIGN.COM

NOTE:
 GRISAKLES ARE CENTERED ON 30"
 5 FT BACK FROM THE EXISTING FENCE
 AND ARE SPACED 17' APART. FIELD
 CULVERTS ARE REQUIRED MAINTAIN A
 MINIMUM OF 8' BETWEEN OBSTACLES.
 MAINTAIN MINIMUM OF 5" MULLCH DEPTH
 (COMPACTED) BELOW OBSTACLES AS
 DETAILED IN COURSE PLAN.

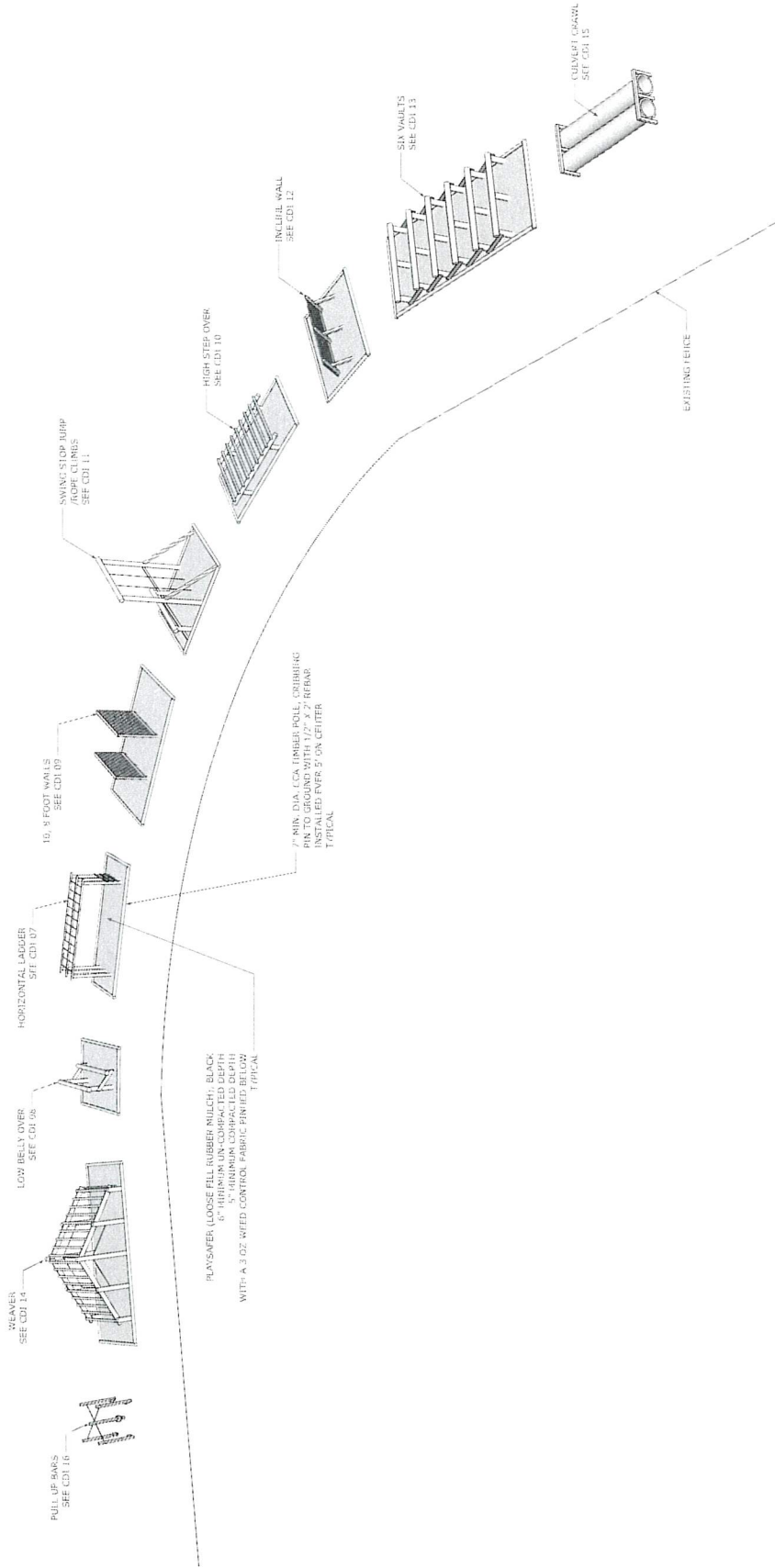

LINCOLN UNIVERSITY
 903 LAFETTE ST.
 JEFFERSON CITY, MISSOURI, 65101
 FOR CONSTRUCTION

COURSE PLAN

DATE: June 11, 2023

DO NOT SCALE

CDI 04

ISOMETRIC VIEW
 SCALE: NTS

01



CHALLENGE DESIGN
 1777 N. W. 10TH AVENUE
 PINEHED, NORTH CAROLINA
 27076-8090
 704.776.8090
 CHALLENGEDESIGN.COM

GENERAL STRUCTURAL NOTES

DRAWINGS SHOW TYPICAL AND CERTAIN SPECIFIC CONDITIONS ONLY. FOR DETAILS NOT SPECIFICALLY SHOWN, PROVIDE DETAILS SIMILAR TO THOSE SHOWN. CONTRACTOR SHALL VERIFY ALL DIMENSIONS, ELEVATIONS AND SITE CONDITIONS PRIOR TO STARTING WORK. CONTACT ENGINEER, AS APPROPRIATE, IF CONFLICTING OR PROHIBITIVE CONDITIONS ARE ENCOUNTERED.

THE DESIGN, ADEQUACY AND SAFETY OF ERECTION, BRACING, SHORING, TEMPORARY SUPPORTS, ETC., IS THE SOLE RESPONSIBILITY OF THE CONTRACTOR. ANY BRAND SPECIFIC MATERIALS MAY BE SUBSTITUTED BY AN EQUIVALENT PRODUCT BY AN ALTERNATIVE MANUFACTURER IF APPROVED BY THE ENGINEER OF RECORD, U.S.A. ALL CONSTRUCTION SHALL CONFORM TO ALL APPLICABLE FEDERAL, STATE, AND LOCAL BUILDING CODES, ORDINANCES, AND REGULATIONS.

ALL CONSTRUCTION SHALL COMPLY WITH CURRENT ASSOCIATION OF CHALLENGE COURSE TECHNOLOGY STANDARDS AND INDUSTRY BEST PRACTICES. DO NOT SCALE DRAWINGS. WRITTEN DIMENSIONS OR NOTATION TAKES PRECEDENCE OVER SCALED DIMENSIONS.

ALL DRAWINGS ON THESE DOCUMENTS ARE INTENDED TO BE TYPICAL AND ONLY REPRESENTATIONAL AND SHALL APPLY TO SIMILAR OR LIKE CONDITIONS. ALL OMISSIONS OR CONFLICTS BETWEEN VARIOUS ELEMENTS OF THE DRAWINGS, ENGINEERING OR DESIGN SHALL BE BROUGHT TO THE ATTENTION OF THE PROJECT MANAGER IMMEDIATELY AND PRIOR TO PROCEEDING WITH ANY WORK INVOLVED.

DESIGN CRITERIA

1. ANSI/APA 103 2019 CHALLENGE COURSE AND CANOPY/ZIP LINE TOUR STANDARD.
2. ANSI/APA 105 2015 NATIONAL DESIGN SPECIFICATION FOR WOOD CONSTRUCTION.
3. ASCE 7-10 MINIMUM DESIGN LOADS FOR BUILDINGS AND OTHER STRUCTURES.
4. IBC INTERNATIONAL BUILDING CODES

LOADS

LIVE LOAD 40 PSF

DEAD LOAD 10 PSF

BUILDINGS AND OTHER STRUCTURES THAT REPRESENT A LOW HAZARD TO HUMAN LIFE IN THE EVENT OF FAILURE, INDICATING THIS COURSE SHALL NOT BE OCCUPIED IN ANY WIND EVENTS, IF EXISTING STRUCTURES ARE TO BE DEMOLISHED, OR DEMOLISHED, OR DEMOLISHED, THE COURSE SHALL BE FULLY INSPECTED BEFORE OPERATION COMMENCES. ANY REPAIRS DUE TO AN ENVIRONMENTAL EVENT OR SIMILAR SHALL BE MADE BY THE OWNER.

E-ALL PROTECTION NOTES

LIFE LINES SHALL BE PERMANENTLY INSTALLED AND USED AS PART OF A COMPLETE PERSONAL FALL ARREST SYSTEM UNLESS THE SUPERVISION OF A QUALIFIED PERSON MAINTAINS A SAFETY FACTOR OF AT LEAST TWO AND APPROXIMATES TO WHICH LIFE LINES ARE ATTACHED AND SHALL BE CAPABLE OF SUPPORTING AT LEAST 5,000 LBS PER EMPLOYEE ATTACHED, OR DESIGNED, INSTALLED AND USED AS PART OF A COMPLETE PERSONAL FALL ARREST SYSTEM UNDER THE SUPERVISION OF A QUALIFIED PERSON.

TIMBER POLES NOTES

TIMBER POLES SHALL BE SOUTHERN YELLOW PINE (SYP) OR DOUGLAS FIR AND CLASS 2 MINIMUM PER ANSI 03.1-2015. OBSTACLES SHALL BE CONSTRUCTED WITH NEW (UNREUSED) UTILITY POLES. POLES SHALL BE TREATED WITH DECAY RESISTANT MATERIAL SUCH AS CHROMATED COPPER ARSENITE (CCA), ANKONA COPPER QUATERNARY (ACQ), OR COPPER BORON AZOLE (CBA).

WOOD NOTES

SEE DRAWING DETAIL FOR DIMENSIONAL DEPTH AND ADDITIONAL INFORMATION.

POLES

- A. TO BE GRADED FOR EXTERIOR USE
- B. TO BE TREATED FOR WESTERN HEMLOCK OR SOUTHERN YELLOW PINE
- C. TO BE TREATED FOR CONTACT WITH SOIL
- D. TO BE TREATED FOR CONTACT WITH SOIL

DIMENSIONAL LUMBER

- A. TO BE PRESSURE TREATED BY DOUGLAS FIR OR SOUTHERN YELLOW PINE
- B. MULTIPLY ALL DIMENSIONS TO BE TREATED BY THE ABOVE METHODS WITH 1/2" ADDITIONAL
- C. ALL DIMENSIONAL LUMBER TO BE IN CONTACT WITH GROUND TO BE RATED FOR GROUND CONTACT OR COATED WITH ROOFING TAR
- D. ALL DIMENSIONAL LUMBER TO BE IN CONTACT WITH GROUND TO BE RATED FOR GROUND CONTACT OR COATED WITH ROOFING TAR

ENGINEERED LUMBER

- A. TO BE GRADED FOR EXTERIOR USE
- B. TO BE GRADED FOR EXTERIOR USE

FRAMING ACCESSORIES/HARDWARE

- A. TO BE GRADED FOR EXTERIOR USE
- B. TO BE GRADED FOR EXTERIOR USE

WIRE ROPE NOTES

WIRE ROPE SHALL BE 3/8" GALVANIZED AIRCRAFT CABLE (GAC), OR IF COMPROMISE OR GREATER QUALITY. WIRE ROPE PROPERTIES:

- A. ALL WIRE ROPE IS TO BE HOT DIP GALVANIZED
- B. 3/8" AIRCRAFT CABLE (GAC)
- C. 14-KN LBS BREAKING STRENGTH

CONNECTIONS AND BENDING RADI ARE TO COMPLY WITH THE WIRE ROPE TECHNICAL BOARD - WIRE ROPE USERS MANUAL. FIRST GRIP CABLE CLIPS OR COPPER ZINC-FERRULES MAY BE USED IN LIEU OF U-BOLT CABLE CLIPS.

SEE INDIVIDUAL EVENT TOWER OR DETAIL SHEETS FOR SPECIFIC WIRE ROPE SIZES AS THEY VARY THROUGHOUT THE COURSE DESIGN.

GENERAL LUMBER NOTES

DESIGN STANDARDS:

- A. AMERICAN FOREST AND PAPER ASSOCIATION, "NATIONAL DESIGN SPECIFICATION FOR WOOD CONSTRUCTION" (ANSI/APA NDS-2015) WITH "NDS SUPPLEMENT, 2015 EDITION. 2015 EDITION.
- B. AMERICAN FOREST AND PAPER ASSOCIATION, "ENGINEERED WOOD CONSTRUCTION GUIDE" AND "DESIGN SPECIFICATION" (LATEST EDITIONS).
- C. STRUCTURAL COMPOSITE LUMBER (SCL) EVALUATED IN CONFORMANCE WITH ASTM D-454 WITH DESIGN VALUES RECOGNIZED IN EVALUATION REPORTS BY ICC EVALUATION SERVICE (ICC-ES). (ICC-ES) OR PROJECT REPORTS ISSUED BY THE ENGINEERED WOOD ASSOCIATION.

ALL SCANS SHALL BE TO THE AMERICAN SOUTHWEST WOOD LUMBER STANDARD, 1520-15. ALL WOOD STRUCTURAL MEMBERS SHALL BE SOUTHERN YELLOW PINE NO. 2 FT (MAXIMUM MOISTURE CONTENT OF 19% MAX).

ALL NUTRIENT MEMBERS SHALL BE FASTENED WITH (3) NAILS 2 1/2" X 3" SCREWS AT 16" O.C. STAGGERED AND ARE TO BE BOLTED TOGETHER WITH (2) 1 1/2" THRU BOLTS AT 36" O.C. AND ADJACENT TO ANY HUS OR LSSU HANGERS.

BOLTED CONNECTIONS:

- A. BEAMS ARE TO HAVE THE FOLLOWING MINIMUM BOLTED CONNECTIONS:
 - 1. 4" X 6" PRESSURE TREATED (PT) - (1) 3/4" THRU BOLTS
 - 2. 4" X 6" PRESSURE TREATED (PT) - (1) 3/4" THRU BOLTS
 - 3. 4" X 6" PRESSURE TREATED (PT) - (1) 3/4" THRU BOLTS
 - 4. 4" X 6" PRESSURE TREATED (PT) - (1) 3/4" THRU BOLTS
- B. BOLTS ARE TO HAVE THE FOLLOWING SPACINGS AND EDGE DISTANCES:
 - 1. SPACING BETWEEN BOLTS
 - 2. EDGE DISTANCE TO THE TOP FACE OF THE BEAM
 - 3. EDGE DISTANCE TO THE BOTTOM FACE OF THE BEAM

ALL BOLTS AND SCREWS SHALL BE INSTALLED WITH A MINIMUM CENTER TO CENTER SPACING OF 2D AND END DISTANCE OF 4D. NOTIFY ENGINEER IF SPACING REQUIREMENTS IF SPACING REQUIREMENTS CANNOT BE MET.

LEAD HOLES FOR BOLTS SHALL BE DRILLED WITH A BIT OF THE SAME NOMINAL DIAMETER AS THE BOLT +1/16".

LEAD HOLES FOR LAG SCREWS SHALL BE DRILLED PER NDS.

ALL BOLTS, CARTRIDGE BOLTS, LAG SCREWS, EXPANSION BOLTS, AND DRYWALL BOLTS SHALL BE INSTALLED WITH STANDARD CUT WASHERS AND NUTS THAT BEAR DIRECTLY ON THE WOOD. ALL BOLTS AND SCREWS SHALL CONFORM TO ANSI/APA STANDARD B1.1. WOOD SCREWS SHALL CONFORM TO B18.6. ALL BOLTS SHALL CONFORM TO ASTM A307 GRADE A UNLESS NOTED OTHERWISE. THE MINIMUM STRENGTHS FOR LAG SCREWS AND WOOD SCREWS SHALL BE AS NOTED BELOW.

WOOD SCREW DIAMETER-INCHES	MIN. BENDING YIELD STRENGTH (P43)
3/8"	135,000
1/2"	165,000
5/8"	200,000
3/4"	240,000
1"	280,000
1 1/4"	320,000
1 1/2"	360,000
1 3/4"	400,000
2"	440,000

LAG SCREW DIAMETER-INCHES	MIN. BENDING YIELD STRENGTH (P41)
3/8"	70,000
1/2"	90,000
5/8"	110,000
3/4"	130,000
1"	150,000
1 1/4"	170,000
1 1/2"	190,000
1 3/4"	210,000
2"	230,000

ALL BOLTS/LAG SCREWS SHALL BE A307 GRADE C MATERIAL, ZINC OR GALVANIZED COATED PER LAW ASTM B633 OR ASTM A153 CLASS C.

ALL BOLTS FOR STRUCTURAL WORK SHALL BE NOT DRIPPED GALVANIZED COMMON WIRE NAILS UNLESS NOTED OR DETAILED OTHERWISE MEETING ASTM F1667. HOLES SHALL BE PRE-DRILLED WHERE NECESSARY TO PREVENT SPLITTING. NAILS SHALL HAVE THE MINIMUM PROPERTIES SPECIFIED IN THE TABLE BELOW.

NAIL TYPE	SHANK DIAMETER-INCHES	MIN. PENETRATION-INCHES	MIN. BENDING YIELD STRENGTH (P51)
6d	0.113	1.13	100,000
8d	0.131	1.31	130,000
10d	0.148	1.48	160,000
12d	0.165	1.65	190,000
14d	0.182	1.82	220,000
16d	0.199	1.99	250,000
20d	0.250	2.50	310,000

FASTENERS SHALL BE CORROSION RESISTANT WOOD SCREWS OR NAILS.

NOTICES NOT EXCEEDING 2" OF DEPTH ARE PERMITTED FOR SPIN TO POLE CONNECTIONS. THE LENGTH OF THE NOTCH SHALL NOT EXCEED THE DIAMETER +1/2" OF THE POLE IT IS BEING CONNECTED TO.

LINCOLN UNIVERSITY
 903 LAFLETTE ST.
 JEFFERSON CITY, MISSOURI, 65101

FOR CONSTRUCTION

STRUCTURAL NOTES

DATE: June 1, 2023
 DO NOT SCALE

CDI 05



CHALLENGE DESIGN
 11717 W. WILSON AVE.
 PO BOX 219
 PINEOLA, NORTH CAROLINA
 28134
 803.327.6680
 CHALLENGEDESIGN.COM

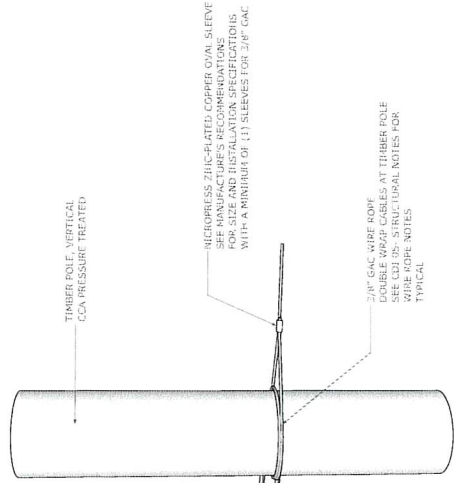

CABLE SWAGE DETAIL
 SCALE: NTS

04

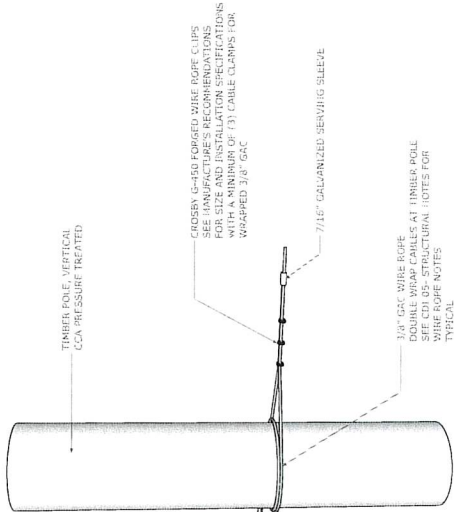

CABLE CLAMP DETAIL
 SCALE: NTS

05

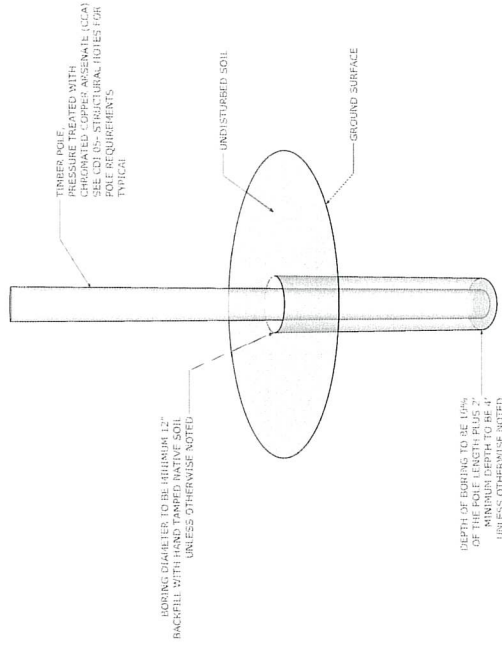

POLE FOOTING DETAIL
 SCALE: NTS

01

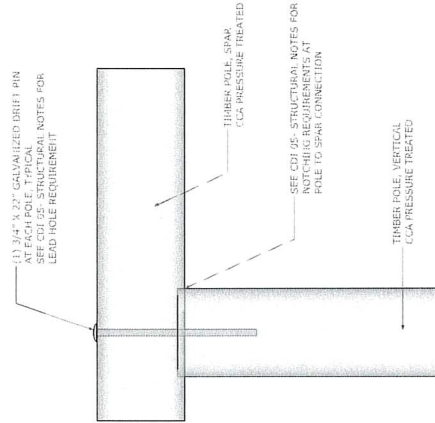

DRIFT PIN CONNECTION
 SCALE: NTS

02

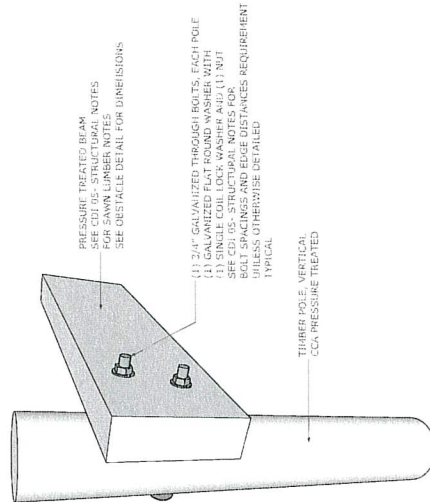

THROUGH BOLT CONNECTION
 SCALE: NTS

03

LINCOLN UNIVERSITY
 903 LAURETTE ST.
 JEFFERSON CITY, MISSOURI, 65101
 FOR CONSTRUCTION

TYPICAL DETAILS

DATE: June 1, 2023

DO NOT SCALE

CDI 06



CHALLENGE DESIGN
 1733 S. POLK ST. #100
 PHOENIX, NORTH CAROLINA
 27560-6689
 CHALLENGEDESIGN.COM

LINCOLN UNIVERSITY
 903 LAFAYETTE ST.
 JEFFERSON CITY, MISSOURI, 65101
 FOR CONSTRUCTION

HORIZONTAL LADDER
 DETAIL

DATE: June 1, 2023
 DO NOT SCALE

CDI 07

NOTE:
 SEE CCI 06 FOR CONCRETE DIMENSIONS,
 MAINTAIN MINIMUM OF 5" NUTLIGH DEPTH
 BELOW OBSTACLE.

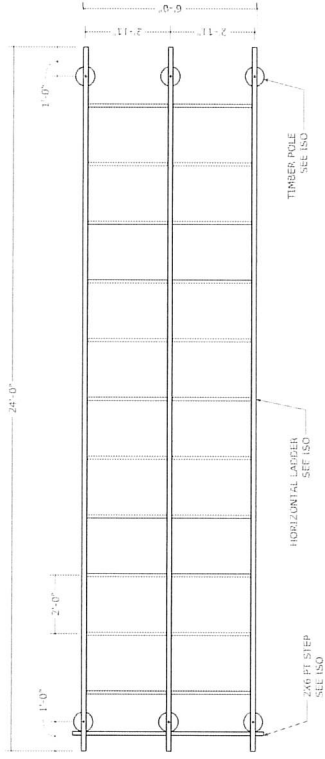

PLAN
 SCALE: 1/8" = 1'-0"

03

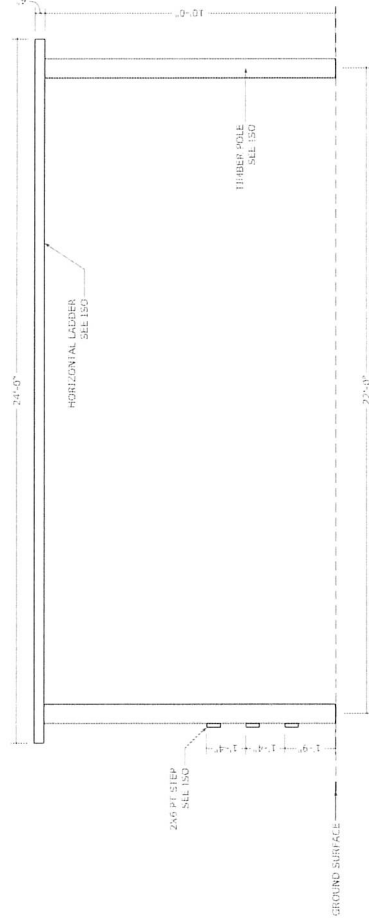

SIDE ELEVATIONS
 SCALE: 1/8" = 1'-0"

01

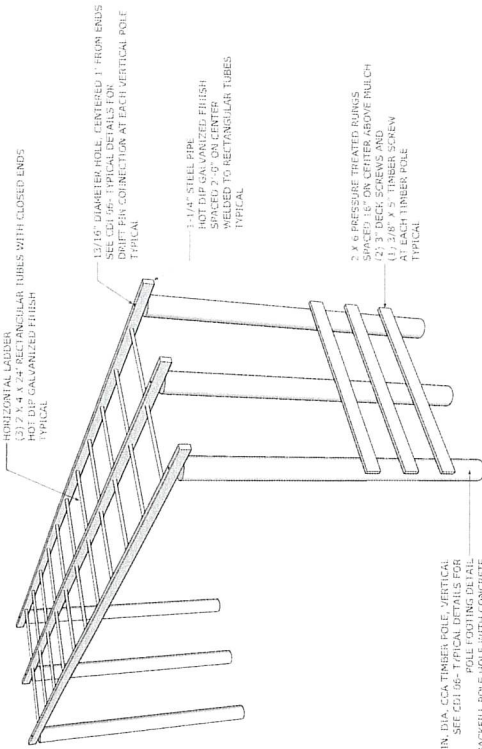

ISO (FRONT)
 SCALE: 1/8" = 1'-0"

04

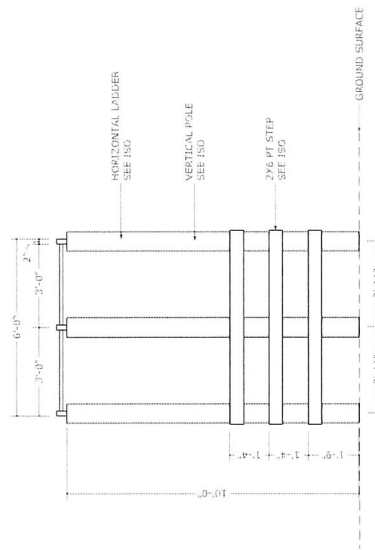

FRONT ELEVATIONS
 SCALE: 1/8" = 1'-0"

02



CHALLENGE DESIGN
 177 N. W. PO BOX 219
 PINEOLA, NORTH CAROLINA
 28134
 803.720.6480
 CHALLENGEDESIGN.COM

LINCOLN UNIVERSITY
 903 LAFAYETTE ST.
 JEFFERSON CITY, MISSOURI, 65101
 FOR CONSTRUCTION

LOW BELLY OVER
 DETAIL

DATE: June 1, 2023

DO NOT SCALE

CDI 08

NOTE:
 SEE CDI 02 FOR CORNER DIMENSIONS.
 MAINTAIN MINIMUM OF 5" NUTCH DEPTH
 BELOW OBSTACLE.

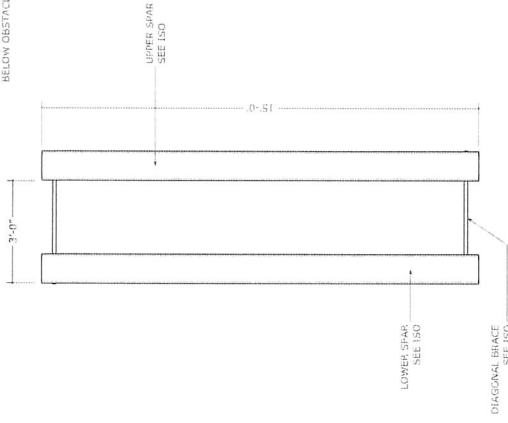

PLAN
 SOCKETS
 SCALE: NTS
 03

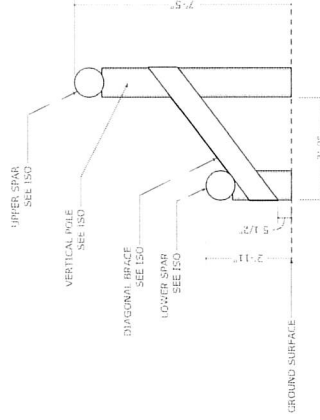

SIDE ELEVATIONS
 SCALE: NTS
 01

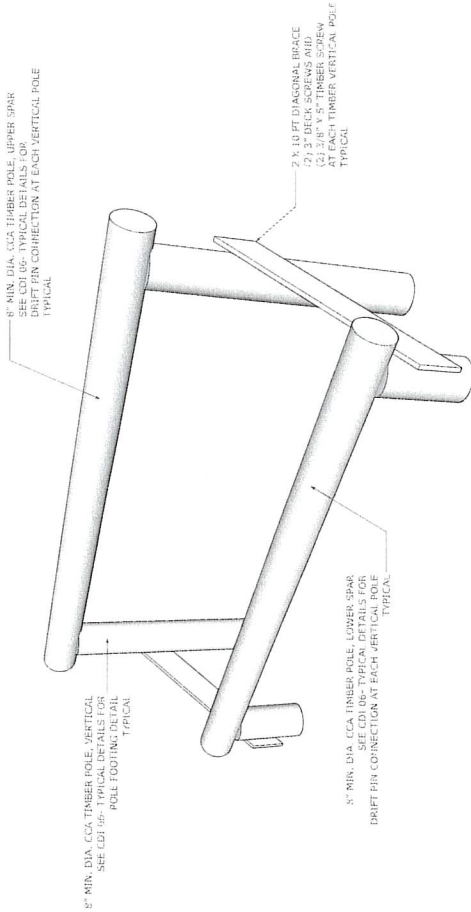

ISO (FRONT)
 SCALE: NTS
 04

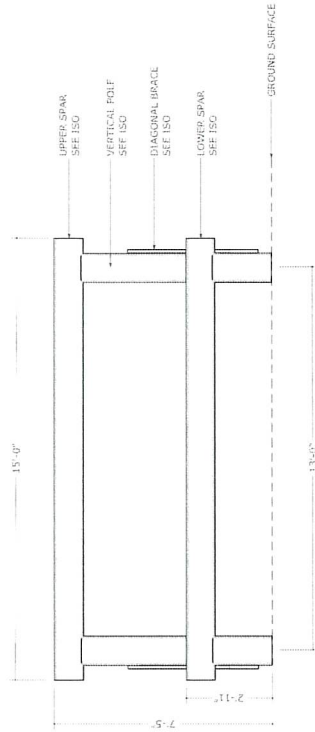

FRONT ELEVATIONS
 SCALE: NTS
 02



CHALLENGE DESIGN
 1718 W. OAK STREET
 PO BOX 219
 PHOENIX, NORTH CAROLINA
 27562-0219
 888.727.4850
 CHALLENGEDESIGN.COM

LINCOLN UNIVERSITY
 903 LAFAYETTE ST.
 JEFFERSON CITY, MISSOURI, 65101
 FOR CONSTRUCTION

10, 8 FOOT LOW WALLS
 DETAIL

DATE: June 11, 2023

DO NOT SCALE

CDI 09

NOTE:
 SEE CDI 05 FOR CHAIRING DIMENSIONS.
 MAINTAIN MINIMUM OF 5" NULCH DEPTH
 BELOW OBSTACLE

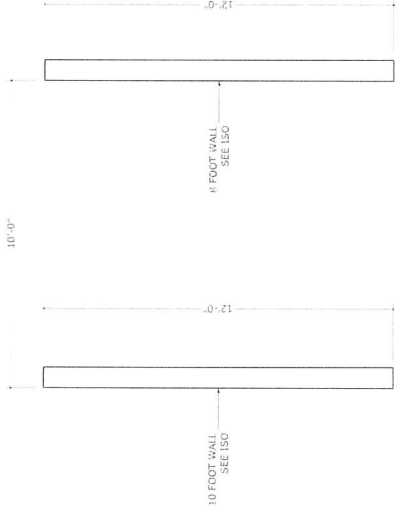

PLAN
 SCALE: NTS
 03

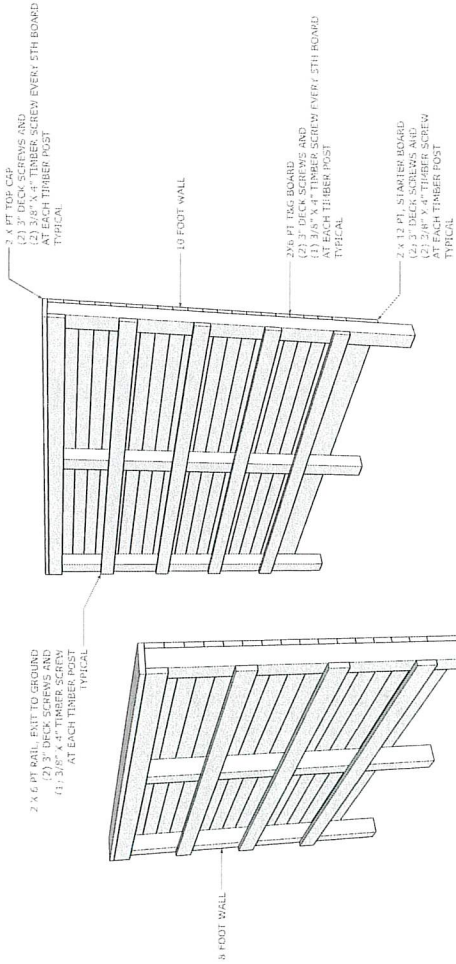

ISO (BACK)
 SCALE: NTS
 04

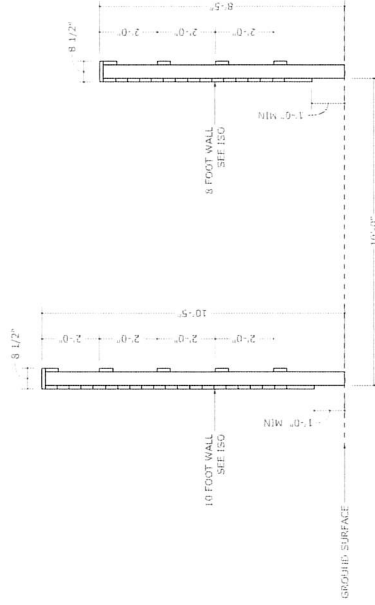

SIDE ELEVATIONS
 SCALE: NTS
 01

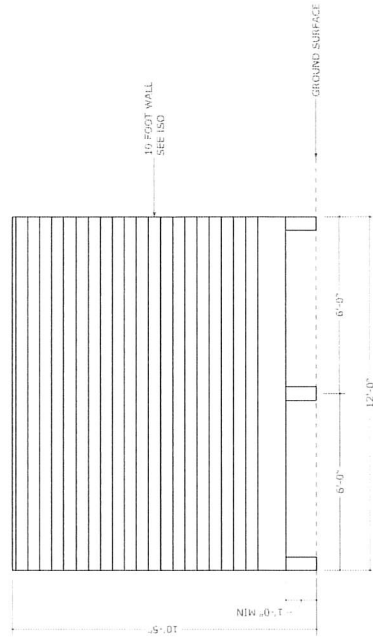

FRONT ELEVATIONS
 SCALE: NTS
 02

THESE PLANS AND ASSOCIATED DOCUMENTS ARE THE EXCLUSIVE PROPERTY OF CHALLENGE DESIGN INC. AND MAY BE REPRODUCED IN WHOLE OR IN PART WITHOUT THE EXPRESS WRITTEN CONSENT OF CHALLENGE DESIGN INC. ANY REPRODUCTION OR TRANSMISSION OF THESE DOCUMENTS WITHOUT THE WRITTEN CONSENT OF CHALLENGE DESIGN INC. IS STRICTLY PROHIBITED. THESE DOCUMENTS ARE FOR ONE TIME USE ONLY. ANY FURTHER USE IS SUBJECT TO CONSENT FROM CHALLENGE DESIGN INC. AND MAY BE REPRODUCED IN WHOLE OR IN PART WITHOUT THE EXPRESS WRITTEN CONSENT OF CHALLENGE DESIGN INC.

NOTE:
 SEE CD1 05 FOR CHAIRING DIMENSIONS,
 SPACING AND MINIMUM OF 2" NUTLET DEPTH
 BELOW OBSTACLE

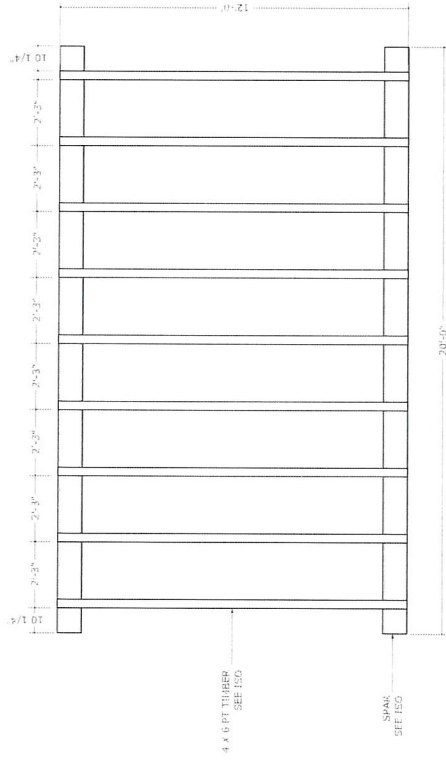

PLAN
 SCALE: 1/8" = 1'-0"

03

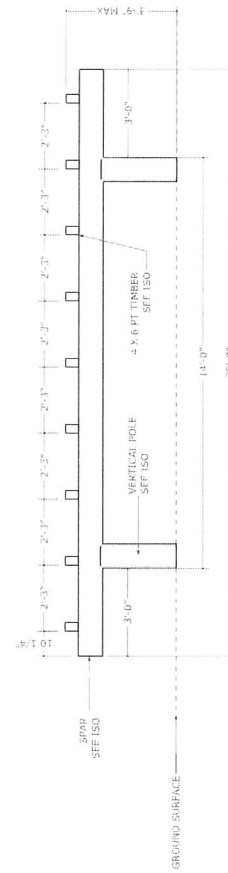

SIDE ELEVATIONS
 SCALE: 1/8" = 1'-0"

01

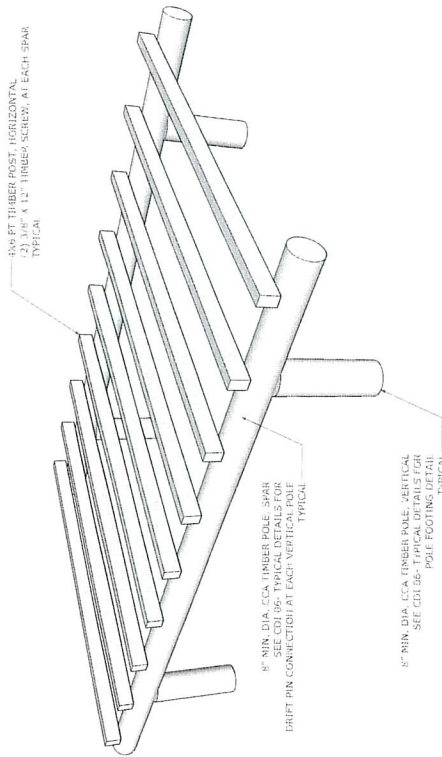

ISO (FRONT)
 SCALE: 1/8" = 1'-0"

04

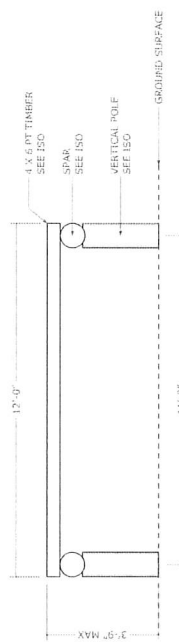

FRONT ELEVATIONS
 SCALE: 1/8" = 1'-0"

02

NOTE:
 SEE CDI 05 FOR CLIMBING CAMELIONS.
 SHANTAR MINIMUM OF 57" NUB LENGTH
 BELOW OBSTACLE.

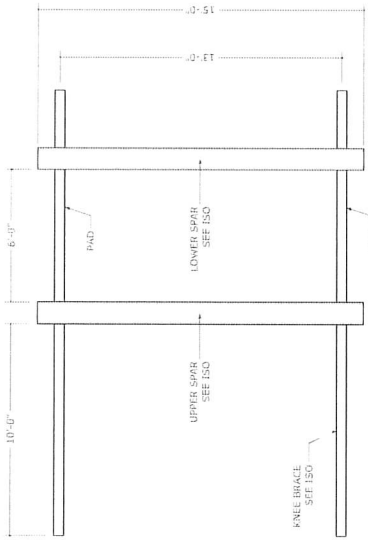

PLAN
 SCALE: INTS

03

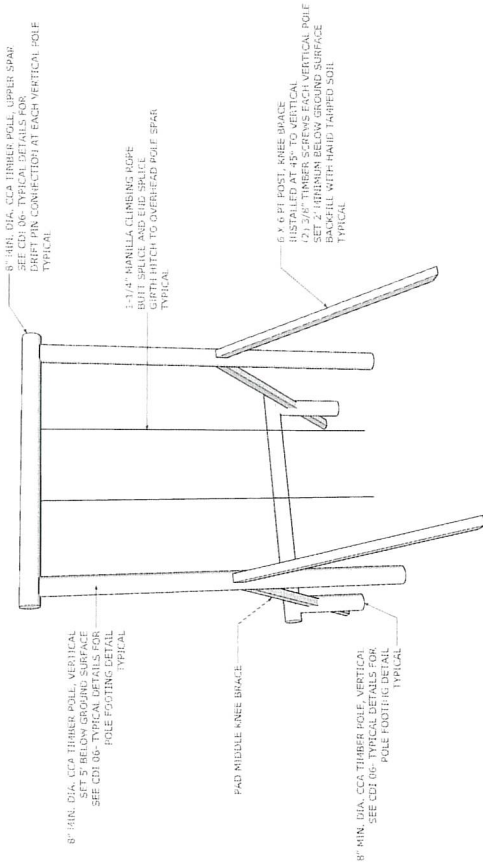

ISO (FRONT)
 SCALE: INTS

04

SWING STOP JUMP
/ROPE CLIMBS
DETAIL

DATE: June 11, 2023

DO NOT SCALE

CDI 11

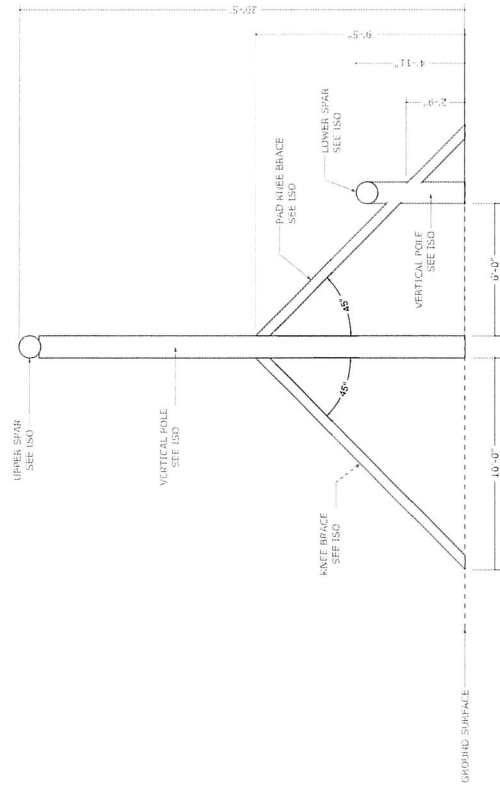

SIDE ELEVATIONS
 SCALE: INTS

01

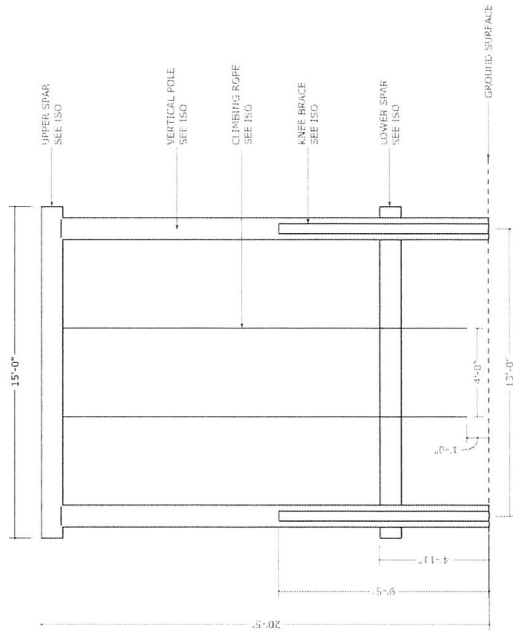

FRONT ELEVATIONS
 SCALE: INTS

02

NOTE:
 SEE CDI 03 FOR DIMENSIONING.
 MAINTAIN MINIMUM OF 5" RAINLICH DEPTH
 BELOW OBSTACLE.

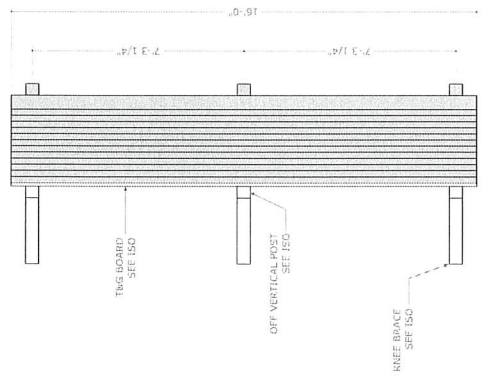

PLAN
 SCALE: 1/8" = 1'-0"

ISO (FRONT)
 SCALE: 1/8" = 1'-0"

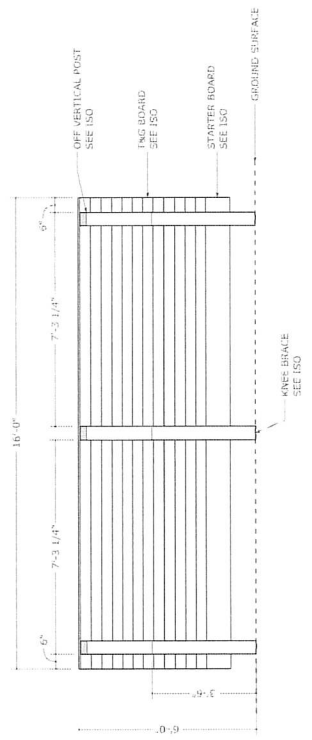
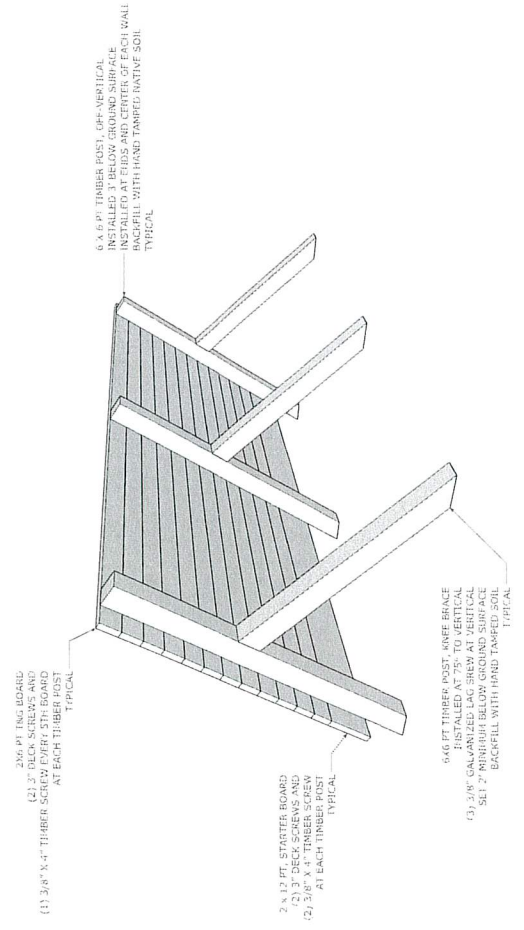

FRONT ELEVATIONS
 SCALE: 1/8" = 1'-0"

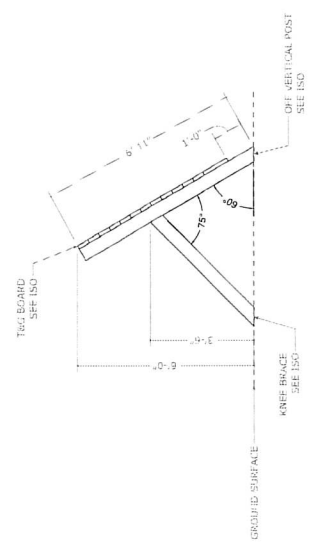

SIDE ELEVATIONS
 SCALE: 1/8" = 1'-0"

NOTE:
 SEE CDI 03 FOR DIMENSIONING,
 PAINTING METHOD OF 5" MULCH DEPTH
 BELOW OBSTACLE.

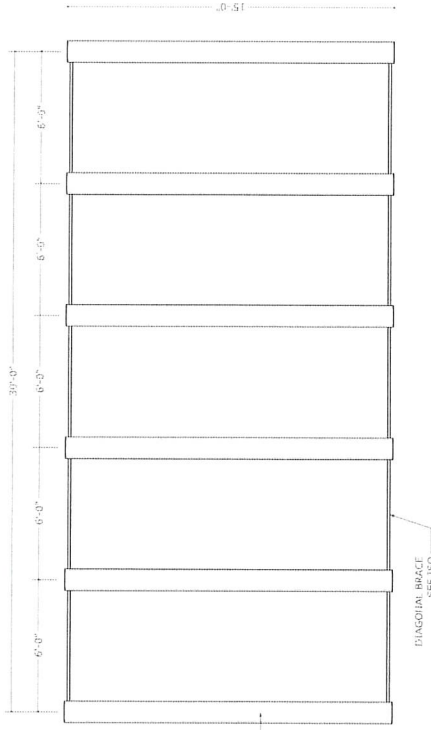

PLAN
 SCALE: NTS
 03

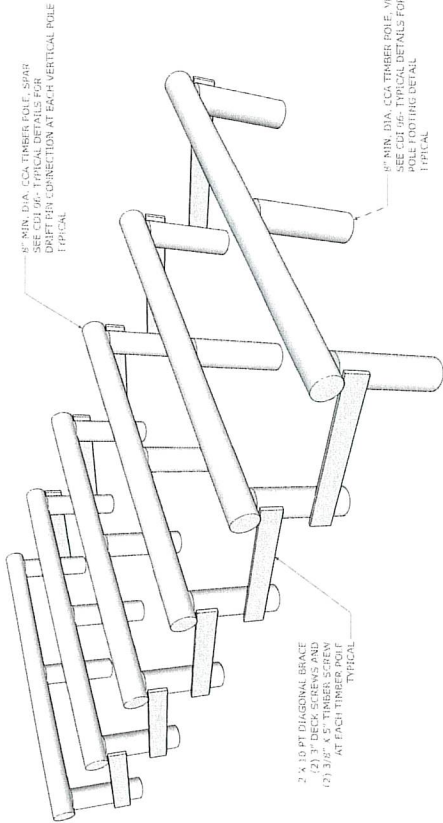

ISO (FRONT)
 SCALE: NTS
 04

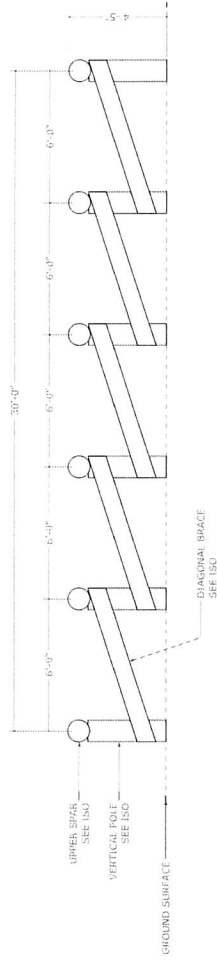

SIDE ELEVATIONS
 SCALE: NTS
 01

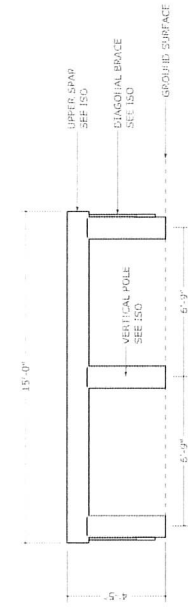

FRONT ELEVATIONS
 SCALE: NTS
 02



CHALLENGE DESIGN
 1715 N. W. 10TH AVE.
 P.O. BOX 219
 PINEHOLM, NORTH CAROLINA
 28062
 803.982.6500
 CHALLENGEDESIGN.COM

LINCOLN UNIVERSITY
 903 LAFFETTE ST.
 JEFFERSON CITY, MISSOURI, 65101
 FOR CONSTRUCTION

WEAVER
 DETAIL

DATE: June 1, 2023
 DO NOT SCALE

CDI 14

NOTE:
 SEE CDI 05 FOR CHAIRING FRAME ISINGS
 MAINTAIN MINIMUM OF 5" MUSHY DEPTH
 BELOW OBSTACLE

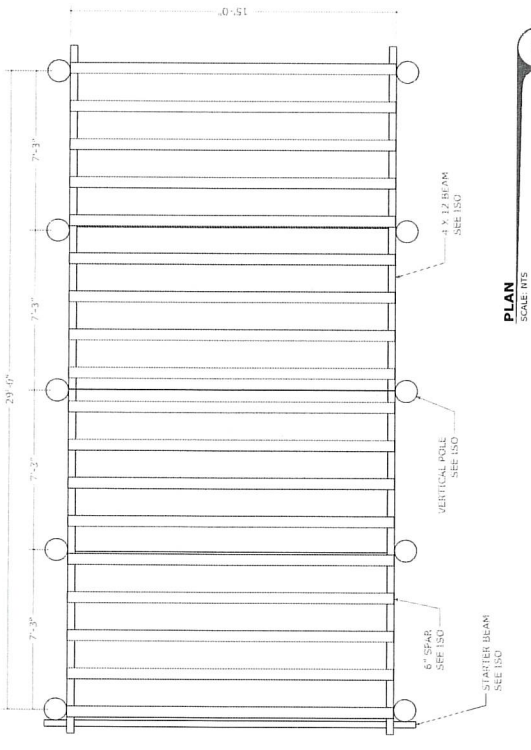

PLAN
 SCALE: NTS
 03

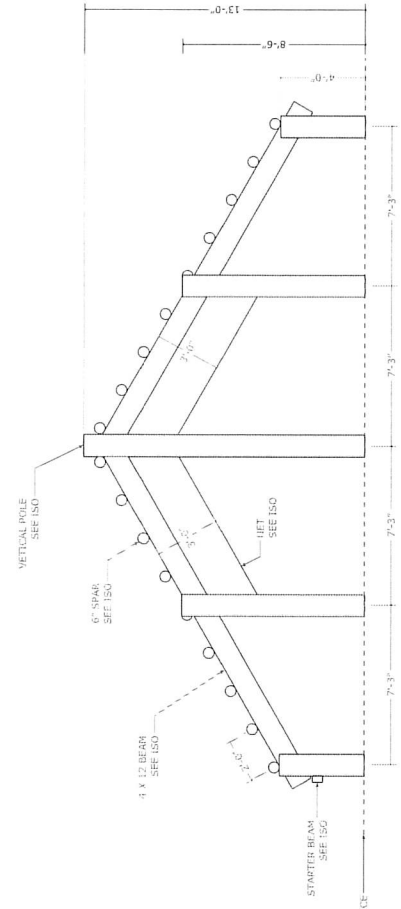

SIDE ELEVATIONS
 SCALE: NTS
 01

2"Ø CMC
 INSTALLED 7" BELOW TOP OF 4" X 12" BEAM
 SEE CDI 06 - TYPICAL DETAILS FOR
 WAVE CONNECTIONS

ATTACH LIFE RATED
 3/8" Ø WIRE ROPE TO CABLE
 PER MANUFACTURER'S CONNECTIONS
 INSTALLATION SPECIFICATIONS

6" MIN. DIA. TIMBER POLE, SPAR
 2" PULLED 2" OFF CENTER
 THROUGH BOLT AT EACH BEAM
 SEE CDI 05 - TYPICAL DETAILS FOR
 THROUGH BOLT CONNECTION
 TYPICAL

4" X 6" FT. TIMBER POST, STARTER BEAM
 (1) 3/4" THROUGH BOLT AT EACH VERTICAL POLE
 SEE CDI 05 - TYPICAL DETAILS FOR
 THROUGH BOLT CONNECTION
 TYPICAL

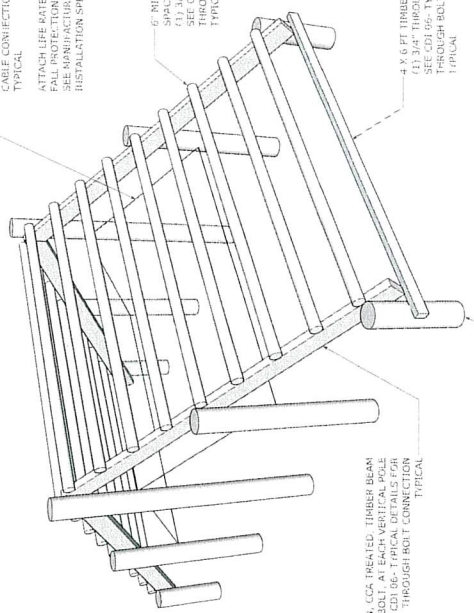

ISO (FRONT)
 SCALE: NTS
 04

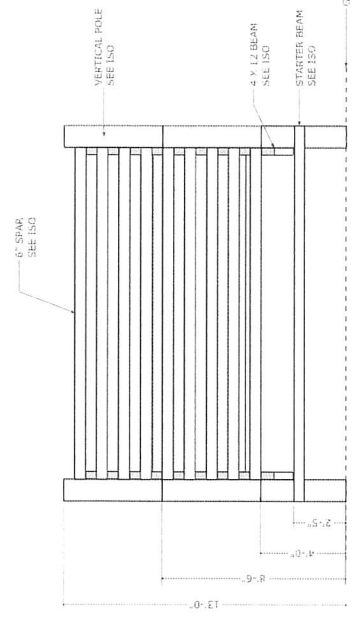

FRONT ELEVATIONS
 SCALE: NTS
 02

THIS PLAN AND ASSOCIATED DOCUMENTS ARE THE EXCLUSIVE PROPERTY OF CHALLENGE DESIGN INNOVATIONS, INC. AND MAY NOT BE REPRODUCED IN WHOLE OR IN PART WITHOUT THE EXPRESS WRITTEN CONSENT OF CHALLENGE DESIGN INNOVATIONS, INC. THESE DOCUMENTS ARE FOR ONE TIME USE ONLY. MULTIPLE USE IS SUBJECT TO CONSENT FROM CHALLENGE DESIGN INNOVATIONS, INC. AND IS SUBJECT TO AN ADDITIONAL FEE PER COPY.

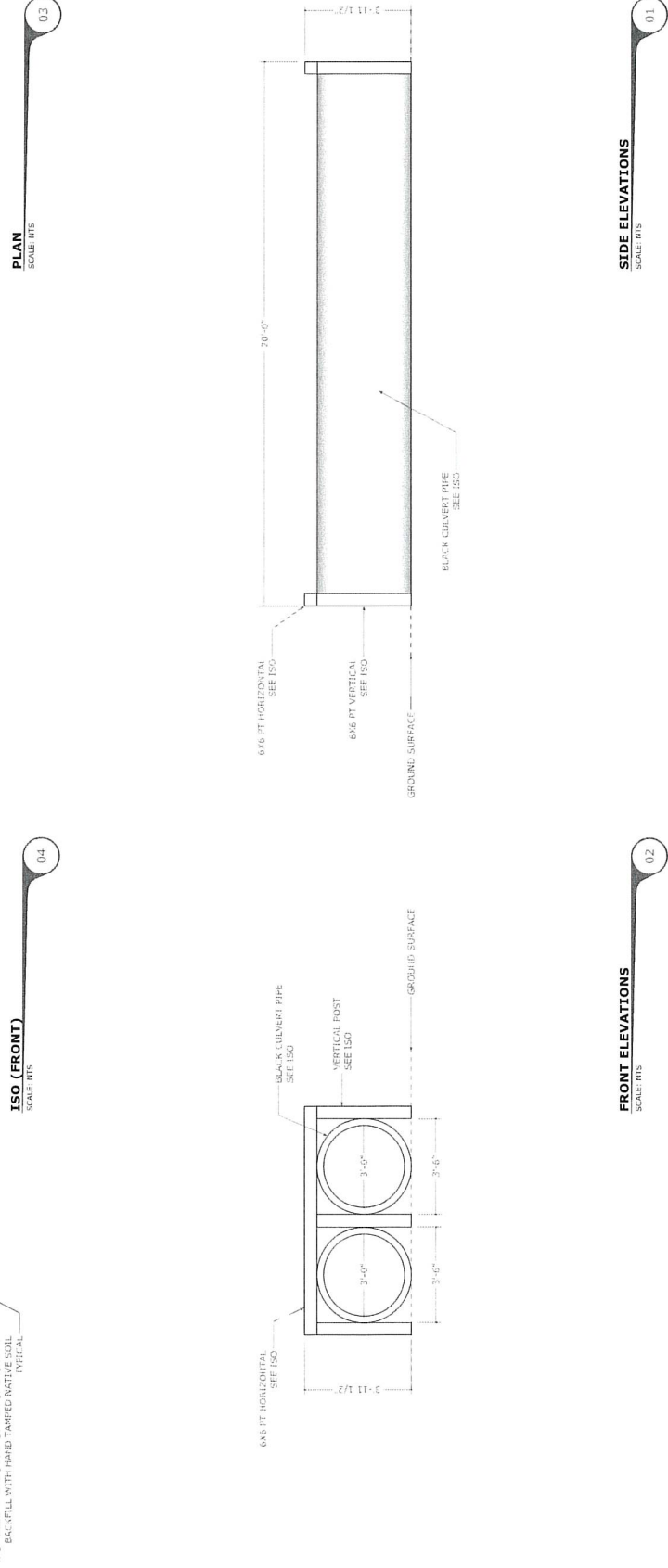
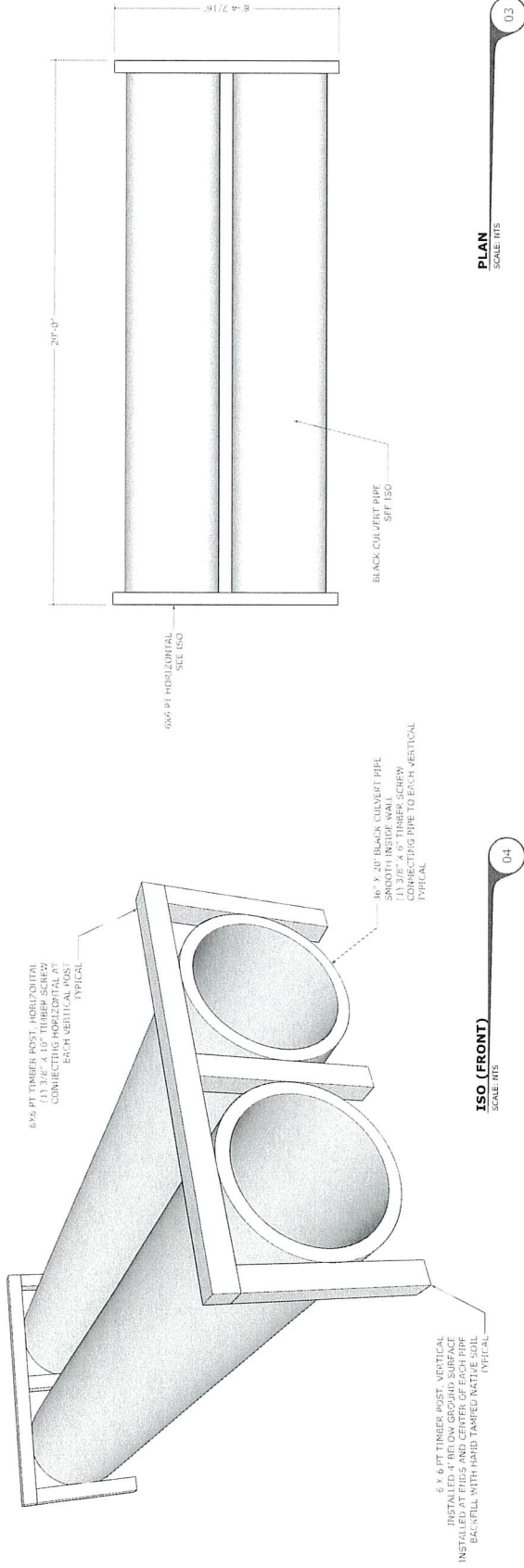



CHALLENGE DESIGN
 1715 S. VANDERBILT BLVD.
 P.O. BOX 219
 PINEBLA, NORTH CAROLINA
 27062
 828-292-8890
 CHALLENGEDESIGN.COM

LINCOLN UNIVERSITY
 903 LAFAYETTE ST.
 JEFFERSON CITY, MISSOURI, 65101
 FOR CONSTRUCTION

PULL UP BARS
 DETAIL

DATE: June 1, 2023
 DO NOT SCALE

CDI 16

1.5"x3" STEEL PIPE WITH CLOSED ENDS
 HOT DIP GALVANIZED FINISH
 SECURE TO VERTICAL POST WITH SET-SCREW
 TYPICAL

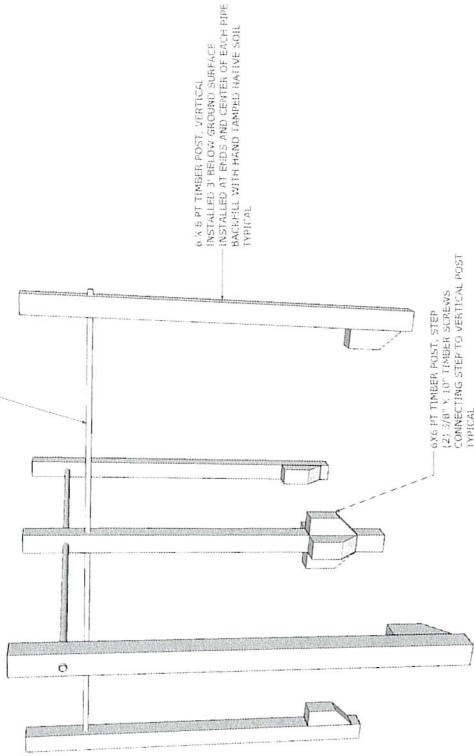

ISO (FRONT)
 SCALE: 1/8"=1'-0"

04

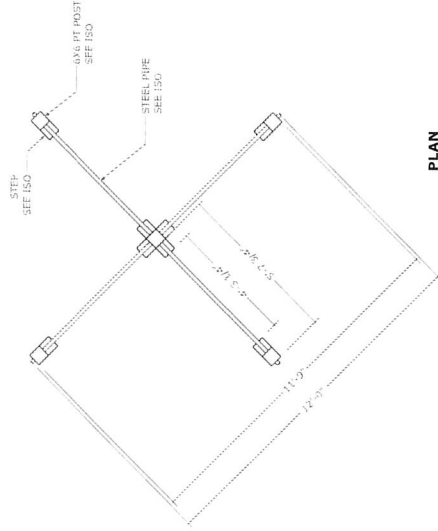

PLAN
 SCALE: 1/8"=1'-0"

03

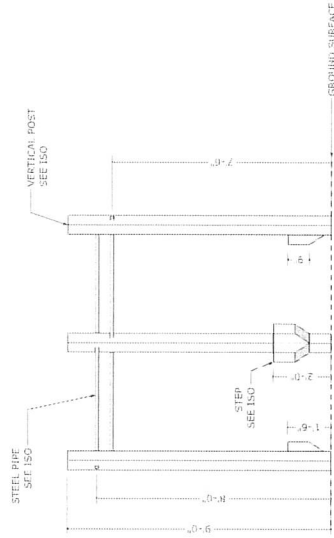

FRONT ELEVATIONS
 SCALE: 1/8"=1'-0"

02

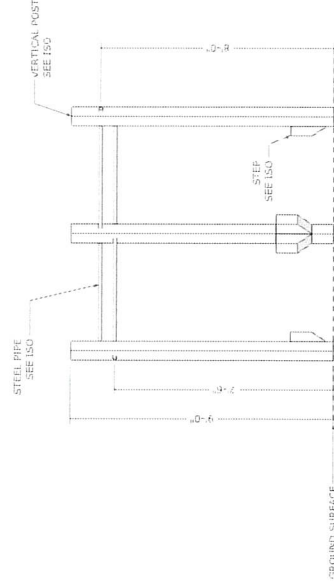

SIDE ELEVATIONS
 SCALE: 1/8"=1'-0"

01